

CLASS[®]

DS 147F-B2

Drive Axle Rear Suspensions
for Ford F550 Cab Chassis
based transit buses and limos

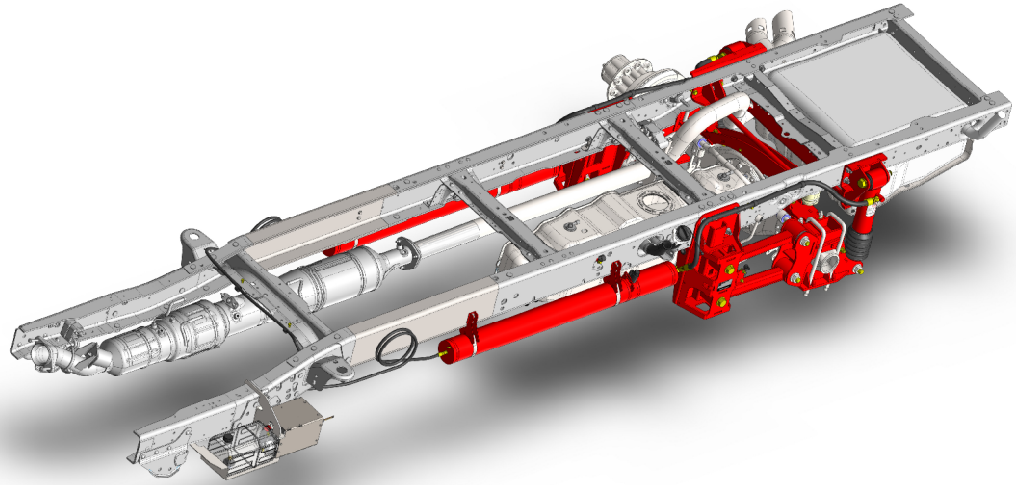

- Non-torque reactive design optimized with CLASS[®]
- Maintains proper driveline geometry through full range of torque inputs reducing driveline noise, vibration, and fatigue
- Variable stiffness and damping adjusted automatically and instantaneously based on road conditions without driver intervention
- Does not require modification to exhaust
- Compact package space claim
- 14,700 lbs GAWR for Ford F550 SuperDuty



Compressible Liquid Adaptive Suspension System

DS147F-B2 Drive Axle Rear Suspensions for Ford F550 Cab Chassis based Transit Buses and Limos

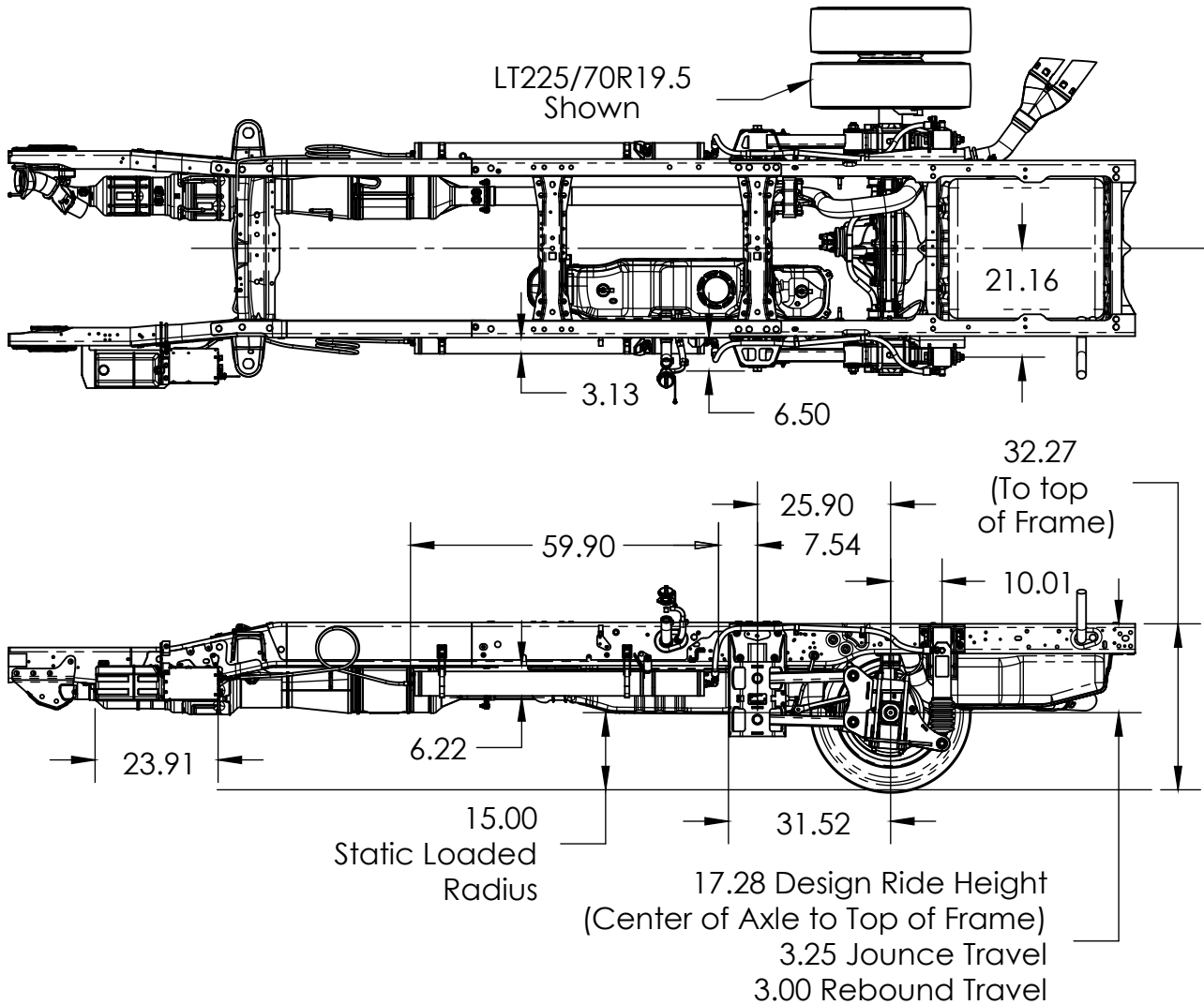

**Engineered suspension solutions for
your ride and handling issues.**



LiquidSpring™ LLC

3416 Rascal Drive
Lafayette, IN 47909

Phone: 765-474-7816

Fax: 765-474-7826

Web: www.liquidspring.com